

SPECIFICATIONS

(RoHS Compliant)



Model Number: TNE2A
Part Number: 19020174A
SPEC NUMBER: 26013828A01

Jan 24, 2013

Mechanical Drawing:

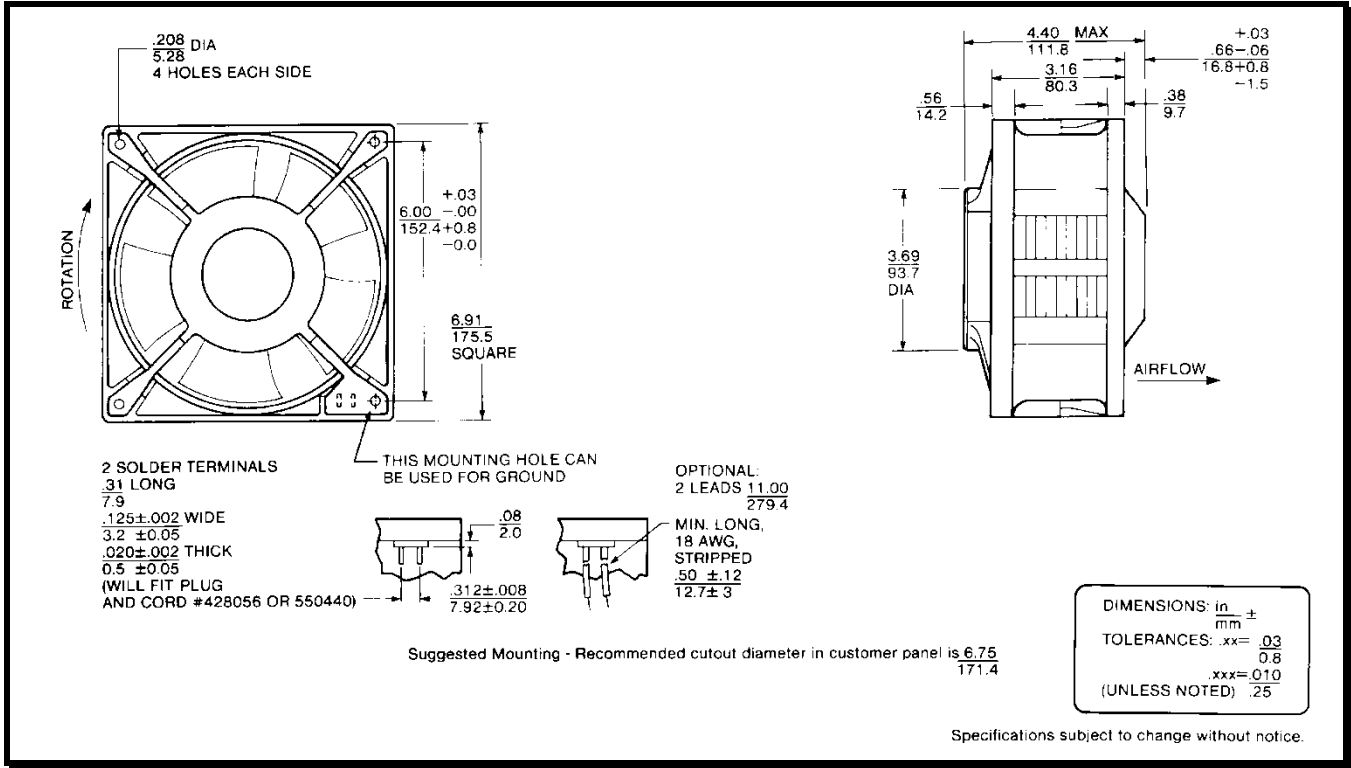

Motor:

Nominal Voltage = 115 VAC
 Frequency = 50 / 60 Hz
 Nominal Running Current = 0.50 / 0.53 Amps
 Max. Locked Rotor Current = 1.25 / 1.35 Amps
 Running Power = 50 / 56 Watts
 Average Speed = 2820 / 3480 RPM
 Bearings = Ball
 Air Flow = 280 / 340 CFM
 Acoustic = 61.6 / 65.4 dBA

Construction:

Venturi: Plastic, Black, UL 94V-0
 Propeller & Cover: Plastic, Black, UL 94V-0

Life Expectancy:

This fan is designed for continuous duty life of 25,000 hours at 40°C.

Additional Features:

Permanent Split Capacitor
 Automatic Reset Thermal Protector
 Thermal Shutdown Protection
 Class B Insulation
 Operating Temperature: -10°C to 70°C
 Storage Temperature: -40°C to 85°C

Termination:

0.125" Terminals

Agency Approvals:

UL, CE